

An Automated Vibrating-Tube Densimeter for Measurements of Small Density Differences in Dilute Aqueous Solutions¹

L. Hnědkovský² and I. Cibulka^{2,3}

The core of the automated apparatus is a high-temperature high-pressure densimeter with a metal vibrating tube designed for accurate flow measurements of densities of liquids in the temperature range from 298 to 573 K and at pressures from 0.1 MPa up to 30 MPa. The densimeter is being employed for a study of dilute solutions of aqueous solutions of organic substances where the density difference {solution–water} is a primary experimental quantity. Consequently, partial molar volumes of solutes at infinite dilution in water are evaluated from the measured data. Two sampling sections are connected in series in the filling line of the densimeter. One of them is employed for manual filling of the measured sample into a sampling loop using a syringe. The other section allows fully automated measurement of up to 12 samples in one run. The recorded data are evaluated after the automated run is completed.

KEY WORDS: aqueous solutions; densimeter; density; high temperature; high pressure; partial molar volume.

1. INTRODUCTION

Vibrating-tube densimeters are widely used for measurements of volumetric properties of fluids, particularly liquids. High precision, simple operation, low volume of samples needed, and measurements in a flow regime are main advantages of this method. Besides the commercially available

¹Paper presented at the Fifteenth Symposium on Thermophysical Properties, June 22–27, 2003, Boulder, Colorado, U.S.A.

²Institute of Chemical Technology, Technická 5, 166 28 Prague, Czech Republic.

³To whom correspondence should be addressed. E-mail: ivan.cibulka@vscht.cz

models (Anton Paar, Sodev Inc.), there are several densimeters developed and constructed in laboratories over the world, which are mostly designed for use at elevated temperatures and pressures [1–8]. A computer-controlled vibrating-tube densimeter was described recently [9]. The well-known principle of the vibrating-tube densimeters is based on mechanical oscillations of a U- or V-shaped glass or metal tube filled with a fluid sample. Oscillations are close to the resonant frequency of the tube and are related to the mass of the tube, i.e., to the density of a fluid inside the tube. Stationary oscillations of the tube are maintained by the electromagnetic force, generated by means of a drive system, acting on the tube. The input signal for the drive system is obtained from a pick-up system that converts mechanical oscillations of the tube into an electrical signal. The difference between the density of a solution, ρ , and that of a pure solvent (water), ρ_0 , in the vibrating tube is related to the respective periods of mechanical oscillations of the tube, τ , τ_0 , according to the following equation, based on a model of the harmonic oscillator:

$$\rho - \rho_0 = K(\tau^2 - \tau_0^2), \quad (1)$$

where K is a calibration constant dependent on temperature and slightly on pressure. The value of the calibration constant is determined by measurements of the oscillation periods for at least two fluids of known density.

Vibrating-tube densimeters may work in either a flow or batch regime. In the flow regime, the standard way of filling the sample into the tube is through the use of a sample loop, filled at atmospheric pressure, whose contents are, after pressurization to the experimental pressure, admitted into the filling line using a valve. In a batch mode the densimeter is usually filled with a sample at atmospheric pressure and the sample is then pressurized to the experimental pressure. It is, however, advisable to keep the pressure inside the tube constant during the filling of the densimeter and thus to avoid pressure changes that may cause a drift of the oscillation period.

2. EXPERIMENTAL APPARATUS

2.1. Vibrating-Tube Densimeter

A vibrating-tube densimeter designed for measurements in the temperature range from 298 to 573 K and at pressures from 0.1 up to 30 MPa is described in detail elsewhere [10]. A metal (Hastelloy C) vibrating tube is fixed to the thermostated block of the cell located inside two thermostated jackets, and the entire assembly is placed in a vacuum chamber to

minimize heat losses. The lid of one of the jackets serves as a pre-heater to bring the temperature of a flowing sample to a temperature close to that of the block of the measuring cell. The drive system is based on passing the drive electrical signal directly to the electrically insulated vibrating tube whose tip is located in the magnetic field of a strong permanent magnet. The photo-electric pick-up system employs glass-fiber optics passing through the magnet extenders. Nitrogen gas and water are used for calibrations at each experimental temperature and pressure. Short-term fluctuations of the temperature of the densimeter cell are within 1 mK. The maximum systematic error of the measured density differences $\{\rho(\text{solution}) - \rho(\text{water})\}$ resulting from the densimeter calibration is about 0.15%. The reproducibility of the measurements is better than $\pm 5 \times 10^{-3} \text{ kg} \cdot \text{m}^{-3}$.

The densimeter is incorporated in the filling line [10, 11] that was several times modified. The present stage of the line is shown schematically in Fig. 1. Degassed water from a boiler (WB) is pumped using a high-pressure liquid chromatography pump (HPLC) through the sampling devices (manual MS and automated AS) into the densimeter and then pushes the compressed nitrogen from the waste container (WC) into the thermostated back-pressure regulator (BPR) (a type with a gas dome). Adjustment of the temperature of the regulator within $\pm 0.1 \text{ K}$ minimizes pressure fluctuations in the line caused by the changes of laboratory temperature and enables fine adjustment of pressure in the line. No waste liquid flows through the regulator. Thus, it is protected from corrosion and the damping effect of gaseous nitrogen in the container WC eliminates slight pressure pulses produced by the HPLC pump. Fluctuations of pressure in the line are less than $\pm 0.03 \text{ MPa}$, typically $\pm 0.01 \text{ MPa}$. A sampling loop (SL) may be used to withdraw samples of the liquid passed through the densimeter, and thus the checks of decomposition of the samples are possible. The auxiliary pump PR is used for pressurization of the sample loops (see below) to a pressure close to that in the line. This avoids any sudden pressure changes in the line after a sample is inserted into the flow of compressed water. The three-way switch valve (TV) is used for filling either nitrogen (one of the calibrating fluids) or a cleaning liquid into the line.

2.2. Sampling Devices

There are two sampling devices connected in series in the filling line (Fig. 1). A manual one (Fig. 2) is used to employ one of two sampling loops for inserting the sample into the flow of compressed water. The liquid samples are filled into the loop(s) from syringes, and the valves V1

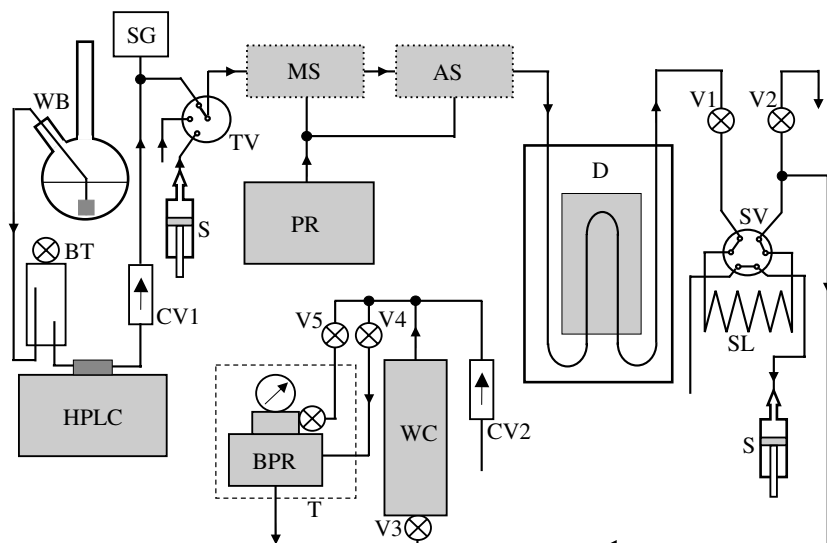

Fig. 1. Schematic diagram of fluid delivery and pressure system. WB, boiler with distilled and demineralized water; BT, bubble trap; HPLC, high-pressure liquid chromatography pump; CV1, CV2, check valves; TV, three-way switching valve; S, syringe; SG, strain pressure gauge; MS, manual sampling block (see Fig. 2); AS, automated sampling block (see Fig. 3); PR, pump for pressurization of sample loops; D, densimeter; SL, SV, sampling loop and a valve; WC, waste liquid container (volume 1 dm³); BPR, back-pressure regulator; T, thermostat of BPR; V1 to V5, shut-off valves.

and V2 are operated manually. Two sampling loops can be used simultaneously when a sample non-miscible with water (generally with a carrier fluid delivered to the system from the high-pressure pump) is measured. In this case an intermediate liquid miscible with both water and the sample is filled into the loop SL1 and the sample from the loop SL2 is inserted into the flow of this intermediate liquid. It is obvious that the experimenter's work is rather time-consuming and routine consisting of filling the sample loops, operating the valves and recording data.

Therefore an automated sampling device (Fig. 3) was developed recently which minimizes the experimenter's effort. A set of up to 12 storage bottles SB (SB1–SB12, only two are shown in the figure) containing measured samples is placed on the metal plate CP, which is cooled, using two Peltier units, to a temperature slightly below the temperature of the laboratory. Cooling of the plate minimizes condensation of vapor on the inner surface of the bottles, and reliable corrections of the solution concentration with respect to evaporation can be evaluated. Samples in the bottles are under a slight overpressure of argon that enables measurements

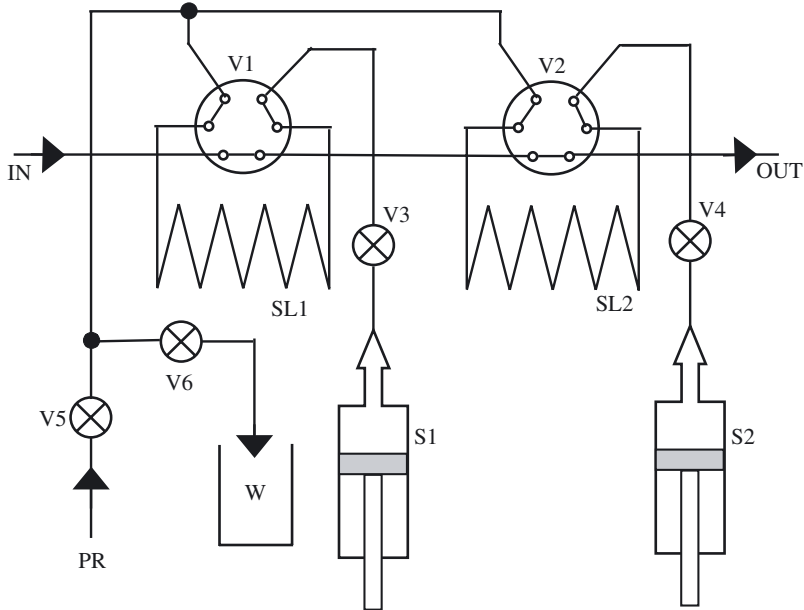

Fig. 2. Manual sampling block (MS in Fig. 1). SL1, SL2, sampling loops; S1, S2, syringes; V1, V2, sampling valves; W, waste; PR, pressurization of the sample loops; V3 to V6, shut-off valves.

of samples sensitive to air. The sample from a particular bottle (SB1 in the figure) is pumped into a sampling loop SL via sampling valves V1 and V2 in the LOAD position using a peristaltic pump (PP). After the sampling loop is filled with the sample (allowing the rest of the previous sample to be washed out), the valve V1 is switched into the INJECT position and the content of the sampling loop is pressurized to a pressure close to experimental pressure using water from an auxiliary high-pressure pump (PR). During the above procedures, degassed water from a high-pressure pump flows into the densimeter and the water baseline is recorded. Then the valve V2 is switched into the INJECT position, the sample from the sampling loop is pushed out from the loop into the densimeter, and the sample plateau is recorded. The valve V3 is then switched over to the next position, valves V1 and V2 are switched into the LOAD positions, and the procedure is repeated for the next sample. The valves (V1, V2, V3) and the peristaltic pump are controlled by a computer (PC). The automated run with 12 samples, each being measured three times (three consecutive cycles of measurements of all 12 samples), takes about 18 hours. Since the targeted measurement is the difference between the density of a solution

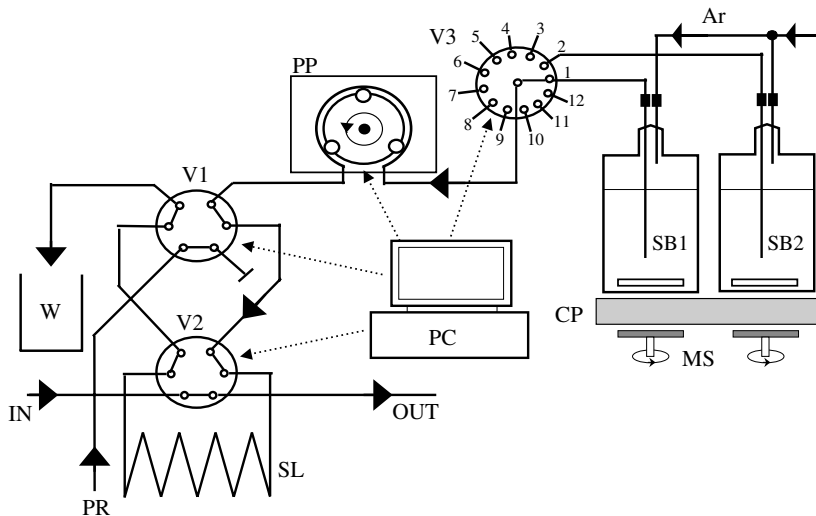

Fig. 3. Automated sampling block (AS in Fig. 1). V1, V2, sampling valves (3×2); V3, one-to-twelve switch-over valve; SL, sampling loop; PC, personal computer; PR, pressurization of the sample loop; PP, peristaltic pump; W, waste; SB1, SB2, ... , SB12, storage bottles with samples (only two bottles are shown); CP, cooled plate; MS, magnetic stirrers; Ar, inlet of argon under slight overpressure. The positions of valves shown in the figure (V1 and V2 in LOAD position, V3 switched to SB1) correspond to the stage of filling the sample loop with sample 1.

and that of water, a bottle with water is always one of those connected to the automated apparatus and the density difference is evaluated as the difference between the density of a solution and the density of water, both saturated with argon. The presence of dissolved argon causes a change of density ranging from $+5 \times 10^{-3} \text{ kg} \cdot \text{m}^{-3}$ at 298 K to $-2.5 \times 10^{-2} \text{ kg} \cdot \text{m}^{-3}$ at 573 K. This effect might be regarded as similar for dilute aqueous solutions and pure water, and therefore the density difference employed for evaluation of partial molar volumes is not affected.

The computer (PC) serves not only to control the automated sampling device but also to record all necessary data from the densimeter (real time, oscillation period of the vibrating-tube, temperature, pressure). The data are written into a file and evaluated after the automated run is completed. A typical record for 12 samples is shown in Fig. 4. Water and 11 samples of dilute solutions of two organic solutes (ethanol and 1-propanol) in water were installed into the sampling device. The samples were connected to the valve V3 (Fig. 3) in the order with minimal differences in concentration between consecutive samples. Usually three rounds are performed within one run, i.e., each sample is measured three times.

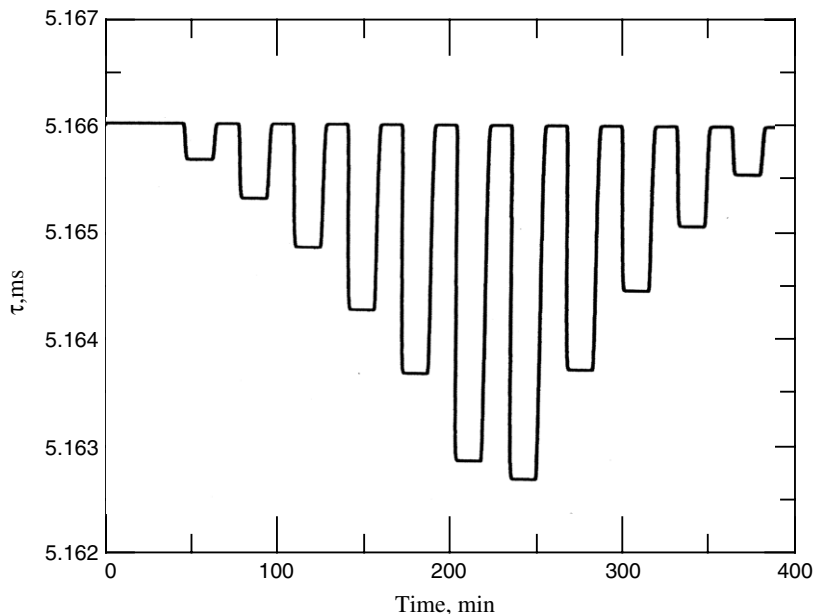

Fig. 4. Time record of the period of tube oscillations τ for an automated run with 12 sample bottles (only one round over the bottles is shown). First sample was water saturated with argon (the change of the period is not visible in the figure due to small density difference), followed by six samples of aqueous ethanol in the order of increasing concentration and five samples of aqueous 1-propanol in the order of decreasing concentration. Flow rate of the liquid in the delivery system was $0.6 \text{ cm}^3 \cdot \text{min}^{-1}$.

Results of measurements of dilute aqueous solutions of several organic solutes using the automated densimeter have been already published (benzene, toluene [12], phenylmethanol, 2-phenylethanol [13]), and others are being prepared for publication (alkanols C_1 to C_3). A comparison with measurements performed previously using the manual sampling device revealed significantly better reproducibility when the automated device was used.

3. CONCLUSIONS

Substantial advantages of the automated sampling apparatus are as follows: (i) it operates without any assistance of an experimenter (usually overnight); (ii) it can be used with samples under inert atmosphere which might be important for measurements of solutes sensitive to air; and (iii) since the storage bottles are never opened (the bottles containing prepared

solutions are stored with the lids with both tubes closed), the corrections of concentration related to the evaporation of the samples in the bottles can be evaluated with a high reliability even for volatile solutes. On the other hand, only samples miscible with water can be measured automatically using the present arrangement.

ACKNOWLEDGMENTS

This work was supported by the Czech Ministry of Education, Youth and Sports (Fund MSM223400008). Thanks are expressed to Mr. František Hrazdára for his careful mechanical work.

REFERENCES

1. H. J. Albert and R. H. Wood, *Rev. Sci. Instrum.* **55**:589 (1984).
2. R. H. Wood, C. W. Buzzard, and V. Majer, *Rev. Sci. Instrum.* **60**:493 (1989).
3. J. M. Simonson, C. S. Oakes, and R. J. Bodnar, *J. Chem. Thermodyn.* **26**:345 (1994).
4. J. G. Blencoe, S. E. Drummond, J. C. Seitz, and B. E. Nesbitt, *Int. J. Thermophys.* **17**:179 (1996).
5. R. F. Chang and M. R. Moldover, *Rev. Sci. Instrum.* **67**:251 (1996).
6. C. Xiao, H. Bianchi, and P. R. Tremaine, *J. Chem. Thermodyn.* **29**:261 (1997).
7. V. Hynek, M. Obšil, V. Majer, J. Quint, and J.-P. E. Grolier, *Int. J. Thermophys.* **18**:719 (1997).
8. W. Hakin, D. C. Daisley, L. Delgado, J. L. Liu, R. A. Marriott, J. L. Marty, and G. Tompkins, *J. Chem. Thermodyn.* **30**:583 (1998).
9. E. C. Ihmels, C. Aufderhaar, J. Rarey, and J. Gmehling, *Chem. Eng. Technol.* **23**:409 (2000).
10. V. Hynek, L. Hnědkovský, and I. Cibulka, *J. Chem. Thermodyn.* **29**:1237 (1997).
11. J. Jedelský, L. Hnědkovský, and I. Cibulka, *J. Chem. Thermodyn.* **31**:27 (1999).
12. P. Hynčica, L. Hnědkovský, and I. Cibulka, *J. Chem. Thermodyn.* **35**:1905 (2003).
13. L. Striteská, L. Hnědkovský, and I. Cibulka, *J. Chem. Thermodyn.* **36**:401 (2004).